



# DE Series for Video Surveillance Best Practices Guide

Deploy and Configure DE Series for Video Surveillance



## Abstract

Video surveillance solutions using Lenovo® DE Series storage offer a highly scalable repository for video recording. This guide offers best practices for deploying DE Series arrays into video surveillance environments.

**First edition (July 2020)**

**© Copyright Lenovo 2020.**

**LIMITED AND RESTRICTED RIGHTS NOTICE: If data or software is delivered pursuant to a General Services Administration (GSA) contract, use, reproduction, or disclosure is subject to restrictions set forth in Contract No. GS-35F-05925**

## TABLE OF CONTENTS

<b>1</b>	<b>Introduction .....</b>	<b>1</b>
1.1	Publication Scope .....	1
1.2	Audience .....	1
1.3	Why Should You Use DE Series for Video Surveillance? .....	1
<b>2</b>	<b>Reference Architecture .....</b>	<b>2</b>
<b>3</b>	<b>VSS Storage Sizing and Selection Guide .....</b>	<b>4</b>
3.1	Lenovo DE Series Storage Sizing .....	4
3.2	Lenovo DE Series Virtualization Sizing .....	8
<b>4</b>	<b>DE Series Storage Considerations .....</b>	<b>9</b>
4.1	Workload .....	9
4.2	Dynamic Disk Pools (DDP) Feature .....	9
4.3	RAID Levels .....	10
4.4	I/O Characteristics .....	10
4.5	High Availability .....	11
<b>5</b>	<b>Lenovo DE Series Storage Provisioning .....</b>	<b>11</b>
<b>6</b>	<b>Server Considerations .....</b>	<b>20</b>
6.1	Multipath I/O Device-Specific Module Installation .....	21
6.2	DE Series LUN Discovery and Preparation .....	21
<b>7</b>	<b>Networking Considerations .....</b>	<b>22</b>
7.1	Traffic Management .....	25
	<b>Where to Find Additional Information .....</b>	<b>26</b>
	<b>Contacting Support .....</b>	<b>26</b>
	<b>Notices .....</b>	<b>27</b>
	<b>Trademarks .....</b>	<b>28</b>

## LIST OF TABLES

Table 1)	VSS components .....	3
Table 2)	Lenovo VSS sizing tool parameters .....	5
Table 3)	DDP pool usable capacity versus number of drives .....	9
Table 4)	Supported controller and expansion enclosure combinations .....	10
Table 5)	Virtual machine common five-drive RAID 6 SSD usable capacities .....	10
Table 6)	DDP pool usable capacity for common virtualization .....	11
Table 7)	Recording server characteristics that Lenovo recommends .....	22

## LIST OF FIGURES

Figure 1) Video surveillance architecture with VMS and Lenovo DE Series arrays.....	3
Figure 2) ThinkSystem System Manager home screen.....	12
Figure 3) Pools & Volume Groups tile. ....	12
Figure 4) Create a DDP pool.....	13
Figure 5) Name the pool and select drives for the pool.....	13
Figure 6) Create a volume.....	14
Figure 7) Create a volume (continued).....	15
Figure 8) Example of final volume configuration.....	16
Figure 9) iSCSI settings.....	16
Figure 10) iSCSI settings (continued).....	17
Figure 11) Create a host.....	17
Figure 12) Create a host (continued).....	18
Figure 13) Host definitions.....	18
Figure 14) Assign volumes to the host. ....	19
Figure 15) Select volumes to assign. ....	19
Figure 16) Host with assigned volumes.....	20
Figure 17) Lenovo ThinkSystem Storage Manager installation. ....	21
Figure 18) Back view of the DE2000 controller. ....	23
Figure 19) Back view of the DE4000 controller. ....	24
Figure 20) Back view of the DE6000 controller. ....	25

# 1 Introduction

Lenovo DE Series storage arrays provide performance, efficiency, reliability, and enterprise-class support for large-scale video surveillance deployments.

All video surveillance management software shares the common feature of recording live video feeds to storage for subsequent replay. This replay helps with forensic analysis or with investigation of people or events that were within the field of view of a single camera or a group of cameras. These video feeds, generated by hundreds or thousands of cameras, are typically configured to record continuously with retention periods in the range of months to years.

## 1.1 Publication Scope

This document provides architecture and deployment guidelines for video surveillance solutions to those who sell, design, or implement such solutions based on Lenovo DE Series storage. It describes the comprehensive functional components that are required to build a video surveillance solution based on Lenovo DE Series storage that can reliably record video and archive video from recording servers. This document identifies the major components and features of a video surveillance system.

## 1.2 Audience

This publication is intended for IT professionals who are responsible for integrating Lenovo DE Series storage systems into existing video surveillance deployments or who design and implement new video surveillance deployments. This audience includes physical-security integrators, video surveillance management software engineers, network and storage system engineers, and architects.

The content in this report is presented with the expectation that these professionals can use this information, combined with their experience and supporting documents, to build an efficient, scalable, and highly available system.

### Targeted Deployments

The targeted deployments for this introduction are large (200 cameras or more) video surveillance installations with significant storage capacity requirements due to retention periods of at least 30 days or the use of HD/megapixel-resolution cameras.

## 1.3 Why Should You Use DE Series for Video Surveillance?

The DE Series architecture supports block-based protocols and can process real-time video applications with high reliability, high performance, and high availability. For these reasons, DE Series is the preferred choice for video surveillance solutions that are designed to use Lenovo storage.

### Solution Benefits

Lenovo DE Series provides the following benefits for large-scale video surveillance deployments:

- **Easy management and monitoring.** The included Lenovo ThinkSystem System Manager software provides a graphical representation of the DE Series storage, with an easy-to-use interface.
- **Easy provisioning.** ThinkSystem System Manager software performs all management tasks for the array without taking the array offline.
- **High availability.** Dual controllers enable nondisruptive controller firmware upgrades, host multipath support, and dual paths to expansion shelves.
- **High performance.** DE Series controllers offer an excellent price-to-performance ratio.
- **Scalability.** With just a couple mouse clicks, you can easily add or expand capacity when you add more drives to your system. The DE6000H supports up to 7.68PB of raw capacity

(using 16TB drives) in an efficient footprint. The entry-level DE4000H supports up to 3.1PB of raw capacity (using 16TB drives) and DE2000H supports up to 1.54PB of raw capacity (using 16Tb drives).

- **Drive health monitoring.** DE Series systems provide proactive monitoring, background repair, and extensive diagnostic features for drives.
- **T10 Standard data integrity and media scan.** This scan detects and corrects data integrity issues that the recording server receives or that are caused by hardware failures on the drives.
- **Data protection.** DE Series systems support RAID levels 0, 1, 10, 3, 5, and 6 for volume groups and for Dynamic Disk Pools (DDP).
- **Certified interoperability.** DE Series systems are [certified to be interoperable](#) with multiple video management software (VMS) providers.

## 2 Reference Architecture

A typical video surveillance solution (VSS) with Lenovo DE Series storage arrays consists of the following main components:

- IP cameras
- Camera network
- Management server or servers
- Recording server or servers
- Failover server or servers (optional)
- Viewing client or clients
- Storage network
- Lenovo DE Series storage array or arrays

Figure 1 shows these components in a standard configuration.

Figure 1) Video surveillance architecture with VMS and Lenovo DE Series arrays.

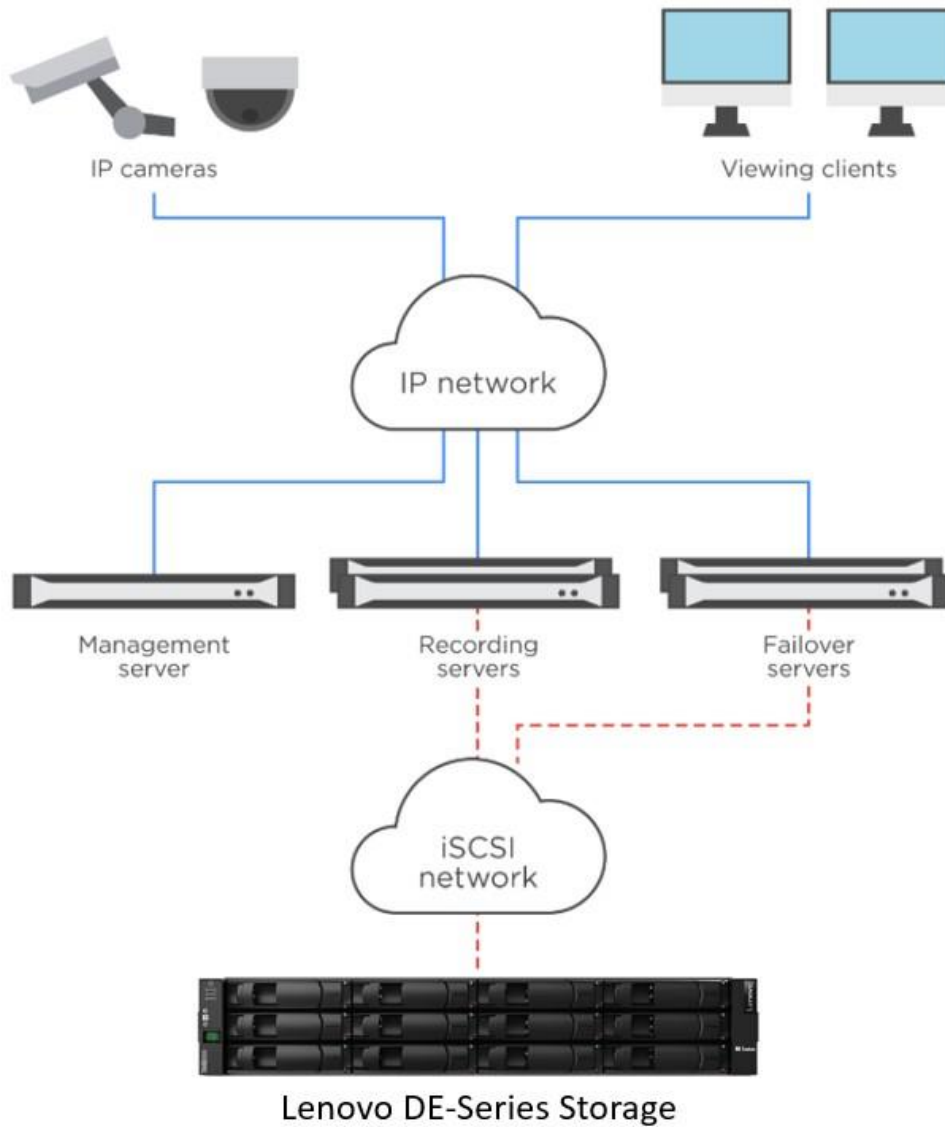

Table 1 provides a brief explanation of each of these components.

Table 1) VSS components.

Component	Description
IP cameras	Provide audio and video streams for live viewing and for recording for later playback by using the VMS.
IP network	Enables communication among camera streams and various VMS components.

Component	Description
Management server	Acts as the central point for configuring all the VMS components.
Recording servers	Are responsible for recording and playback of audio and video streams as per the configuration that the management server dictates.
Failover servers	Provide redundancy against recording server failures (optional).
Viewing clients	Provide live viewing of camera streams or playback of recorded audio and video by the recording servers.
Storage network	Enables communication among the recording and failover servers and the Lenovo DE Series storage arrays. This network is typically iSCSI, but FC and SAS protocols are also supported.
Lenovo DE Series storage arrays	Provide highly available storage for video and audio files from the recording and failover servers.

**Note:** For detailed information about all the supported configurations and additional components, refer to the specific VMS provider that you are using.

The following sections provide general guidelines on how to size and tune VSS components, especially the Lenovo DE Series storage arrays, for optimal results. You should use these guidelines along with the VMS provider recommendations.

### 3 VSS Storage Sizing and Selection Guide

This section highlights various aspects of the VSS that affect its storage needs, along with an example estimation and model selection.

#### System Requirements

The system requirements are specified in a request for proposal (RF) or a quote that is developed by either the end customer or a physical-security integrator who is in contract with the end customer.

The physical-security integrator must work with the physical-security manager to accurately assess specific requirements, including:

- Number, location, and type of cameras; resolution; frame rate; and so on
- Number of recording servers
- Number of cameras per recording server
- Virtualization requirements
- Video management software (VMS) type
- Continuous recording or record on motion
- Retention period and archiving requirements
- Failover design requirements

**Note:** To verify these requirements, the VMS provider's sizer should be referenced.

#### 3.1 Lenovo DE Series Storage Sizing

Each recording server has specific storage needs that are based on the number and type of cameras and the recording parameters that it must support. Contact your salesperson to size VSS storage for your deployment. Your Lenovo salesperson takes into consideration the inputs shown in Table 2 for each camera group and estimates the total amount of storage needed for your entire VSS deployment. Your Lenovo salesperson also has the tools to draw recommendations for the appropriate Lenovo DE series storage products based on your VSS storage sizing needs.



## Storage Estimation for Live and Archived Recording

Table 2 lists the parameters that are needed to estimate VSS storage needed:

Table 2) Lenovo VSS sizing tool parameters.

Parameter	Description
Camera group/number of cameras	VSS site divided into camera groups, with the number of cameras installed in each group; for example, parking lot, office space.
Camera resolution	Average camera resolution of the camera group; for example, 1280x720, 1920x1080.
Compression type	Average compression type of the camera group; for example, H.264-30, H.265-20.
Frames per second (FPS)	Average FPS of the camera group; for example, 15, 30
Motion activity	The likelihood that motion will occur in the field of view of the camera group. For example, low (stairway, emergency exit), high (intersection, subway).
Bit rate	Average bit rate of the camera group in Kbps (if known). <b>Note:</b> This parameter supersedes the resolution, compression type, FPS, and motion activity parameters.
Recorded hours per day	Average hours per day that the camera group will be recording; for example, 12, 24.
Days to retain	Maximum number of days that the video will be saved for the camera group, either under live recording, archived recording, or both.

As an example, for a group of cameras with the following parameters, storage needed is shown below:

### Input parameters:

- Number of cameras: 25
- Resolution: 1920x1080
- Compression type: H.264-30
- FPS: 20
- Motion activity: below average
- Recorded hours per day: 24
- Days to retain: 30

### Storage needed:

- Total throughput: 72.63Mbps
- Total storage: 23.01TiB
- Storage per camera: 0.93TiB

As an example, for a group of cameras with the feed quality information in bitrate, storage needed is shown below:

**Input parameters:**

- Number of cameras: 50
- Bit rate: 2000Kbps
- Recorded hours per day: 24
- Days to retain: 30

**Storage needed:**

- Total throughput: 172.63Mbps
- Total storage: 54.69TiB
- Storage per camera: 0.73TiB

**Note:** In addition to required storage, the throughput estimate also influences the optimal storage model selection for a VSS. For more details, see the Lenovo DE Series Storage Selection section.

**Storage Estimation for Reserved Capacity**

When you define the retention period policy, you must consider the amount of reserved capacity. As a best practice to prevent the “disk full” error condition, each volume that is attached to a recording server should be maintained at approximately 80% utilization.

By using the storage estimate example, following is the reserved capacity estimate:

- Required storage: 192TiB
- Reserved storage:  $(192 \times 0.2) = 38\text{TiB}$

**Storage Estimation for the Failover Server Volume**

Lenovo recommends that you size the volume for each failover server to retain a minimum of 3 to 5 days of video from the recording server. To calculate the size of the failover server volume, divide the capacity of the recording server volume by the site retention period and then multiply by the number of days to retain during failover.

By using the storage estimate example, following is the failover server volume capacity estimate:

- Required storage: 192TiB
- Reserved storage:  $[(192 / 30) \times 5] = 32\text{TiB}$

**Sizing for Archiving**

Generally speaking, the archiving process copies data from one location to another. Therefore, for every initial write, you must read and then write the data again. Also, archiving typically runs on a schedule, so it must be able to archive a day’s worth of data in less than a day. Many users choose to reduce the frame rate for the video that they archive, which saves some percentage of the initial size of the video. Depending on the format, it might be linear savings (MJPEG) or marginal savings (H.264). This approach

reduces the amount of bandwidth that is required to archive on the target volume and reduces the amount of storage capacity that is needed to reserve and to store the video.

As a general rule, you want to ensure that your archiving runs at no less than 1.5x the rate at which the initial recording is providing new data. For example, if your system ingests 100MBps of video data, it should be able to archive at 150MBps or more. This rate provides a margin of safety so that your video can be successfully archived before the drive capacity runs out. If archiving never completes in a timely manner, the VMS is eventually forced to delete data before the configured data expiration. To avoid drive contention, Lenovo also recommends that you archive to a different volume on a different DDP pool instead of archiving to the live recording volume.

### Lenovo DE Series Storage Selection

Lenovo offers various DE Series storage models that can match typical VSS price, performance, capacity and analytics needs. Following are some of the details of these models:

- DE2000H 2U12, DE4000H 2U12, DE4000H 4U60, and DE6000H 4U60 are dual-controller hybrid arrays for capacity needs.
- 4TB, 8TB, 10TB, 12TB and 16TB NL-SAS HDDs are supported.
- DE4000F 2U24 and DE6000F all flash arrays for video analytics needs.
- 800GB and 1.6TB 3DWD SSDs, and 3.84TB, 7.68TB and 15.36TB 1DWD SSDs are supported.
- Traditional RAID volume groups and (RAID 6–based) DDP pools are supported

**Note:** Section 4, DE Series Storage Considerations, provides the pros and cons of using DDP pools over traditional RAID volume groups, as well as the optimal volume layout for recording and failover servers.

Table 3 provides a reference for estimating the number of different capacity drives that are required with DDP to satisfy specific usable capacity needs. You can use this table to extrapolate the additional number of drives that you might need.

**Table 3) DDP pool usable capacity versus number of drives (Note that 1 TiB = 1.099TB and 1 PiB = 1.125PB).**

Number of Drives	DDP (4TB)	DDP (8TB)	DDP (10TB w/Encryption)	DDP (12TB)	DDP (16TB)
12	28.62TiB	56.31TiB	70.16TiB	84.2TiB	112.27TiB
24	62.95TiB	123.89TiB	154.34TiB	185.24TiB	247.03TiB
30	80.13TiB	157.67TiB	196.44TiB	235.76TiB	314.35TiB
48	130.08TiB	255.97TiB	318.9TiB	382.74TiB	510.32TiB
60	164.77TiB	324.23TiB	403.94TiB	484.8TiB	646.40TiB
90	248.6TiB	489.19TiB	609.45TiB	731.46TiB	975.28TiB
120	335.32TiB	659.83TiB	822.05TiB	986.62TiB	1.32PiB
180	502.98TiB	989.75TiB	1.2PiB	1.45PiB	1.93PiB
240	673.52TiB	1.29PiB	1.61PiB	1.94PiB	2.58PiB
480	1.33PiB	2.61PiB	3.25PiB	3.90PiB	5.21PiB

Table 4 provides a reference to determine the supported controller and expansion enclosure combinations that can satisfy specific usable capacity needs in conjunction with Table 3.

**Table 4) Supported controller and expansion enclosure combinations.**

	DE2000H 2U12	DE4000H 2U12	DE4000H 4U60	DE6000H 6U60
Form factor	2U/12 drives	2U/12 drives	4U/60 drives	4U/60 drives
Maximum drives	96	192	192	480
Controller shelf	1	1	1	1
Maximum expansion shelves	3	7	3	7
Total (maximum) number of drive shelves	4	8	4	8
Maximum raw Capacity	1.50PB	3.07PB	3.07PB	7.68PB

**Note:** For a comprehensive list of DE product options, go to [LSST](#) (the Lenovo storage sizing tool) or contact a Lenovo storage sales person. LSST takes into account the throughput requirements of the solution in addition to capacity needs.

### 3.2 Lenovo DE Series Virtualization Sizing

Virtualization is useful in deployments where resource utilization can be pooled and shared. It enables your system to provision resources faster and requires fewer physical servers to manage, all in a simplified interface. Your video surveillance deployment can use virtualization to scale compute, memory, and storage to meet the demands of many types of expansions. For example, you can increase retention, increase frame rate, and add cameras seamlessly.

Lenovo DE Series systems are an excellent choice for the storage behind these virtual environments. DE Series systems give you the option for hybrid storage. With a hybrid approach, virtual machines can use high-performing SSDs and also satisfy VSS requirements with inexpensive, larger-capacity NL-SAS HDDs, all within the same storage system.

This section considers sizing requirements for virtualized video surveillance deployments that differ from bare-metal deployments. [Virtualizing Video Management Systems with Lenovo DE Series Storage](#) provides a comprehensive deployment guide for virtualized video surveillance solutions.

#### Storage Estimation for Virtualization

Use flash media to meet the latency requirements of common virtual infrastructures such as the ESXi virtual machine and the VMS application and OS. Because virtual machines are critical for the health of your overall VSS deployment, Lenovo recommends a RAID 6 dual-drive parity. Lenovo DE Series storage requires a minimum of five drives when you deploy RAID 6.

**Table 5) Virtual machine common five-drive RAID 6 SSD usable capacities (Note that 1 TiB = 1.099TB).**

5 x 800GB SSD	5 x 1.6TB SSD	5 X 3.84TB	5 X 7.68TB	5 X 15.36TB
2.17TiB	4.35TiB	10.46TiB	20.94TiB	41.90TiB

Virtual machine storage reduces the total usable capacities for VSS recording by a minimum of five drives, depending on the capacity that is required for the virtual machines. Table 6 lists usable VSS capacities for common deployments; these capacities include the reduction for common virtualization required storage.

Table 6) DDP pool usable capacity for common virtualization (Note that 1 TiB = 1.099TB and 1 PiB = 1.125PB).

Number of Drives	DDP (4TB)	DDP (8TB)	DDP (10TB w/Encryption)	DDP (12TB)	DDP (16TB)
55	150.32TiB	295.79TiB	368.50TiB	442.28TiB	589.71TiB
85	234.14TiB	460.75TiB	574.02TiB	688.93TiB	918.57TiB
115	320.86TiB	631.39TiB	786.62TiB	944.09TiB	1.26PiB
175	488.52TiB	961.31TiB	1.17PiB	1.40PiB	1.87PiB

## 4 DE Series Storage Considerations

Each video recording server requires one or more volumes (LUNs) to be defined to the OS to archive video files. To configure the DE Series storage array, use Lenovo ThinkSystem System Manager to allocate individual drives to a disk pool or to a volume group.

The minimum number of drives in a disk pool is 11, but the minimum number of drives for a volume group depends on the RAID level. The maximum number of drives for RAID 5 or RAID 6 is 30. The limit for a disk pool is the total population of drives in the array.

During the volume group definition step, you select the RAID level for all drives that are assigned to the volume group. The supported levels of RAID 0, 1, 10, 3, 5, and 6 are for traditional volume groups, and DDP uses RAID 6 stripes that are allocated over 10 of the drives in the pool.

Individual volumes (LUNs) are created and mapped to a host after you define the disk pool or volume group. The performance and sizing requirements of your video recording server and your application software determine the number of drives per volume group or per pool and the number of volumes per group or per pool.

### 4.1 Workload

The performance of storage systems is characterized by I/O operations per second (IOPS) and by throughput in megabytes per second. Network performance is measured in packets per second and the throughput is measured in megabits per second.

When the storage array is used for small random I/O operations from multiple applications, it is important to optimize IOPS. Also in that use case, network packet-per-second performance is usually measured in small (64-byte) packets.

Video surveillance deployments, however, are more concerned with throughput performance than with IOPS. Network video cameras generate large IP packets to the recording servers and write relatively large records to the storage array. Video ingress to the recording servers is over an IP network, and the data rate is typically calculated in megabits per second (Mbps) for IP networks. Therefore, many of the tables in this document list Mbps rather than megabytes per second (MBps).

### 4.2 Dynamic Disk Pools (DDP) Feature

To maintain a consistent level of performance even in the event of drive failure and reconstruction, the Dynamic Disk Pools (DDP) feature is available on DE Series systems. The DDP feature minimizes the performance drop during rebuild, and the rebuild completes more quickly than with a traditional RAID rebuild. Because of the shorter rebuild time with DDP, your exposure to data loss from several drive failures is minimized.

With DDP, you can also add capacity incrementally without having to create new volume groups. You can define a single pool that includes all the drives in your system, or you can define multiple pools for your system. A typical deployment has 30 to 60 drives per pool. Because of these factors, Lenovo recommends DDP as the optimal choice for video surveillance.

### 4.3 RAID Levels

Although DDP is recommended as the go-to choice for video surveillance deployments, RAID 5, RAID 6, or RAID 10 is commonly deployed in the industry. The Nevada Gaming Commission standards, for example, specify that the storage array must not lose data if a single component fails. Although RAID 6 and DDP provide better fault tolerance because they can tolerate two simultaneous drive failures, RAID 5 is often deployed instead because it costs less and still adheres to the standards. Also, if a VSS deployment uses virtualization and the virtual machine storage resides externally, it likely needs a RAID deployment for an all-flash volume group.

RAID 10 is typically used for optimal read performance when it is combined with SSDs. RAID 5 or RAID 6 is used for optimal write performance. On DE Series systems, you implement RAID 10 by selecting RAID 1 with four or more drives.

Some VMS vendors recommend a combination of RAID 10 and RAID 5 in gaming deployments, where a high volume of forensic analysis occurs, and during the most recent minutes or hours of video archives. These designs use RAID 10 for the most recent archive, then, with the tiered storage feature, move video to a RAID 5 volume group for the duration of the retention period.

This design consideration might not be required in environments that have infrequent forensic analysis or where the performance level is such that the RAID 5 or RAID 6 volume group provides acceptable read performance. The education market is one vertical in which archived video is reviewed only if an incident (for example, vandalism or an altercation between students) warrants analysis of the video.

**Note:** When you work with RAID 5 and RAID 10 volume groups, which can handle only one drive failure, you should consider allocating hot spares to reduce your risk of data loss if an additional drive fails.

### 4.4 I/O Characteristics

In many deployments, the video surveillance workload is characterized as exceeding a 90% write workload. In these deployments, video is archived to drive either continuously or based on motion detection and is not reviewed unless an incident occurs that requires analysis. The education market is one example in which archives are viewed infrequently.

The write workload is typically a constant workload per volume (LUN) based on the number of cameras per server.

The read workload is based on the frequency and the number of viewing stations that review archived video. Most video management systems implement analysis tools that enable the operator to fast-forward video. They also include features to intelligently search archived video for motion or for objects in a particular area of the field of view of the camera. These search utilities might examine all archived video between two time periods or every 10th frame. Also, video archives from multiple cameras can be time-of-day synchronized and fast-forwarded.

This read workload might generate I/O requests at many times the rate that the video was originally written to a drive. Write workload is relatively easy to characterize, but read workload is less predictable.

The architecture and configuration of the video management system also affect the workload to the storage array. Systems that implement tiered storage schedule a copy from one volume or directory to another at a recurring interval (such as hourly or daily). During the copy function, the IOPS of the storage array might increase by a factor of 8 or more. This function generates both read and write I/O.

While examining workflow and performance data, video surveillance deployments must first measure the baseline write performance and then consider the frequency that video is read or copied after the initial write.

As an additional note, two types of SCSI offload are available: Windows offloaded data transfer (ODX) and VMware XCOPY, which are both fully supported by Lenovo DE Series controllers. If the OS and VMS application both support these SCSI offload operations, then performance for activities such as archiving between two volumes on the DE Series controller is increased over traditional read and write requests.

## 4.5 High Availability

Real-time applications such as video provide a challenge for physical-security integrators. Any outage or failure between a network video camera and the storage system means that the record of events is lost and cannot be recovered. Implementation of high availability for video surveillance begins with considering the camera placement, the network infrastructure, server and VMS redundancy, and the storage array.

For critical areas, to maintain coverage if a single camera or access layer switch fails, you should implement multiple cameras with overlapping fields of view. Multiple cameras that cover the critical area must be connected to separate access layer switches with redundant uplinks to the core or distribution layer switches. The IP network must implement high-availability network design principles, rapid convergence from link and switch failures, deterministic traffic recovery, and sufficient capacity to adequately service traffic during failures.

VMS features that use local storage in the network video camera, failover recording servers, and a redundant management server protect the availability of the video archives. Hypervisors such as VMware ESXi have native support for link aggregation. For nonvirtual deployments, the Microsoft Failover Cluster Virtual Adapter for Windows Server 2019 supports link aggregation.

The failover drivers are at the center of providing path failure recovery between the server and the storage array. In general, failover drivers implement the following functions:

- Identify redundant I/O paths.
- Reroute I/O to an alternate controller when the controller or data path fails.
- Check the state of the paths to a controller.
- Provide the status of the controller or bus.

For Windows, the failover drivers are a combination of Microsoft Multipath I/O (MPIO) and the Lenovo Storage Manager host installation device-specific module (DSM). DE Series systems support the native multipath feature of VMware ESXi. For more information, see section 6.1, Multipath I/O Device-Specific Module Installation.

### Note:

The DSM is in the Storage Manager for 11.50.x.

The DSM is a separate installer with 11.60.x and later.

In addition to the reliability that pools and volume groups provide, DE Series arrays add an extra level of high availability with their hardware. With redundant controllers, power supplies, ports, and fans, DE Series arrays are built to withstand failure in the rare case that a failure occurs.

## 5 Lenovo DE Series Storage Provisioning

The Lenovo ThinkSystem System Manager is extremely easy to use and is quite intuitive. The example that starts with Figure 2 shows the process of creating a pool, creating volumes, and mapping those volumes. This example uses a DE4000H system with two drive shelves, include 12 8TB NL-SAS drives and 23 900GB HDD.

Figure 2 shows the home screen of ThinkSystem System Manager after you log in to the system from a web browser.

Figure 2) ThinkSystem System Manager home screen.

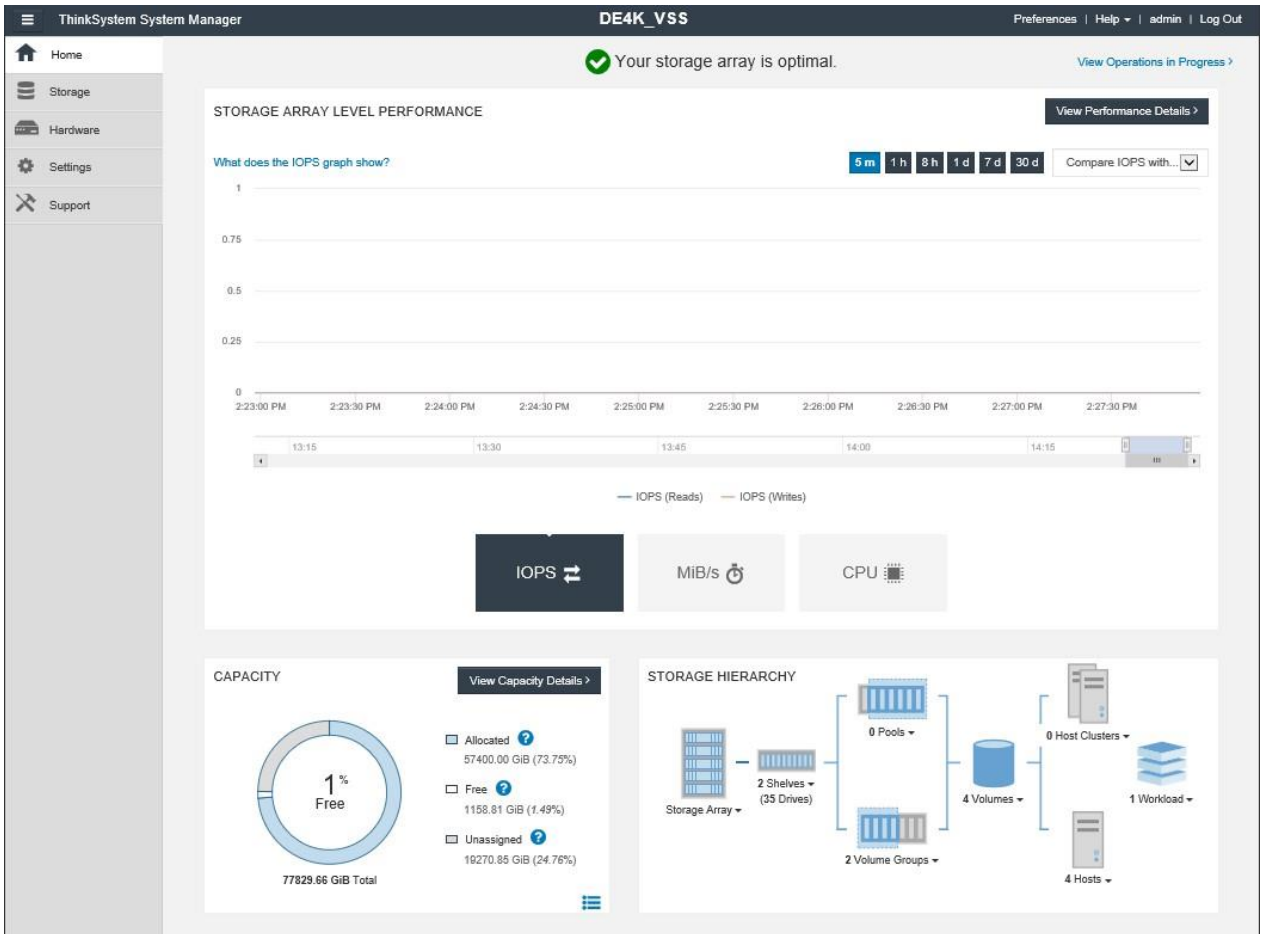

To begin creating your pool, click the Storage tab to the left and then click the Pools & Volume Groups tile as shown in Figure 3.

Figure 3) Pools & Volume Groups tile.

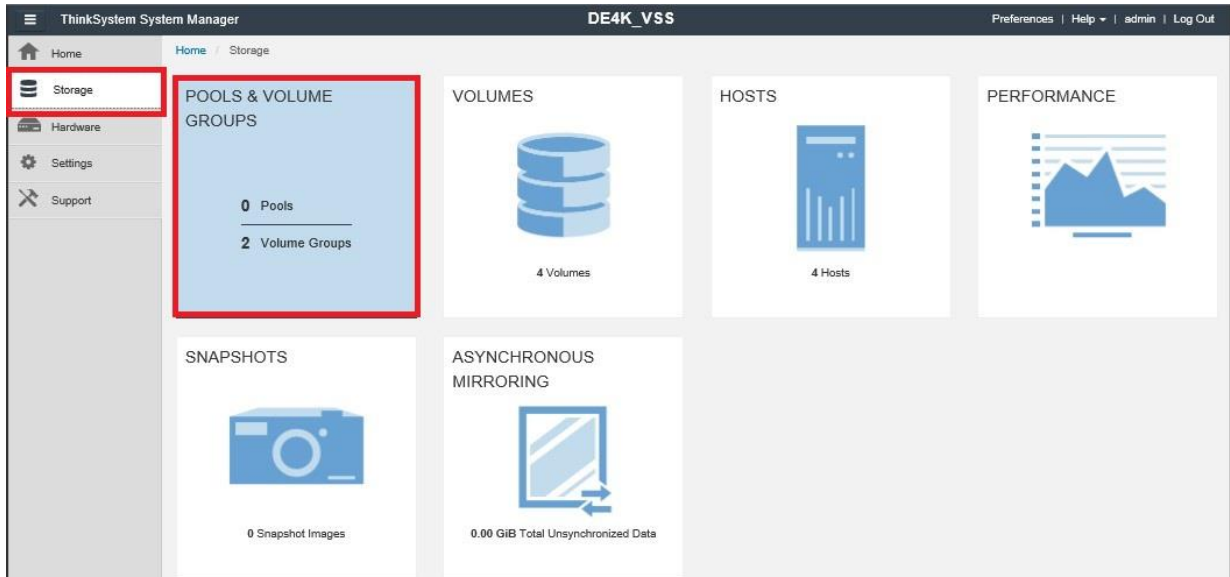



Next, click either the Create drop-down menu or the Create Pool button, shown in Figure 4.

Figure 4) Create a DDP pool.

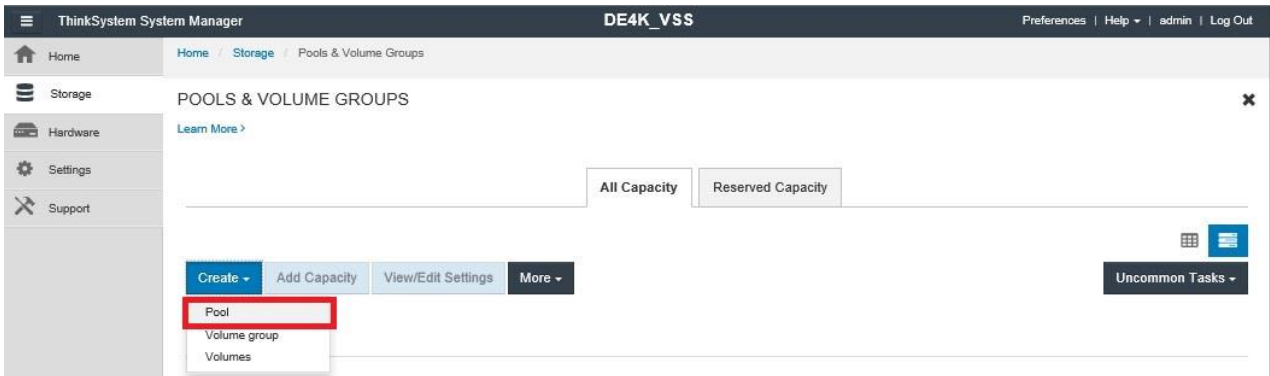

From here, you see a Create Pool dialog box as shown in Figure 5. You must name your DDP pool and select the drives that you want to use for this pool. After you name your pool and select your drives, click the Create button at the bottom right. Your pool has now been created, and you are ready to begin creating your volumes.

Figure 5) Name the pool and select drives for the pool.

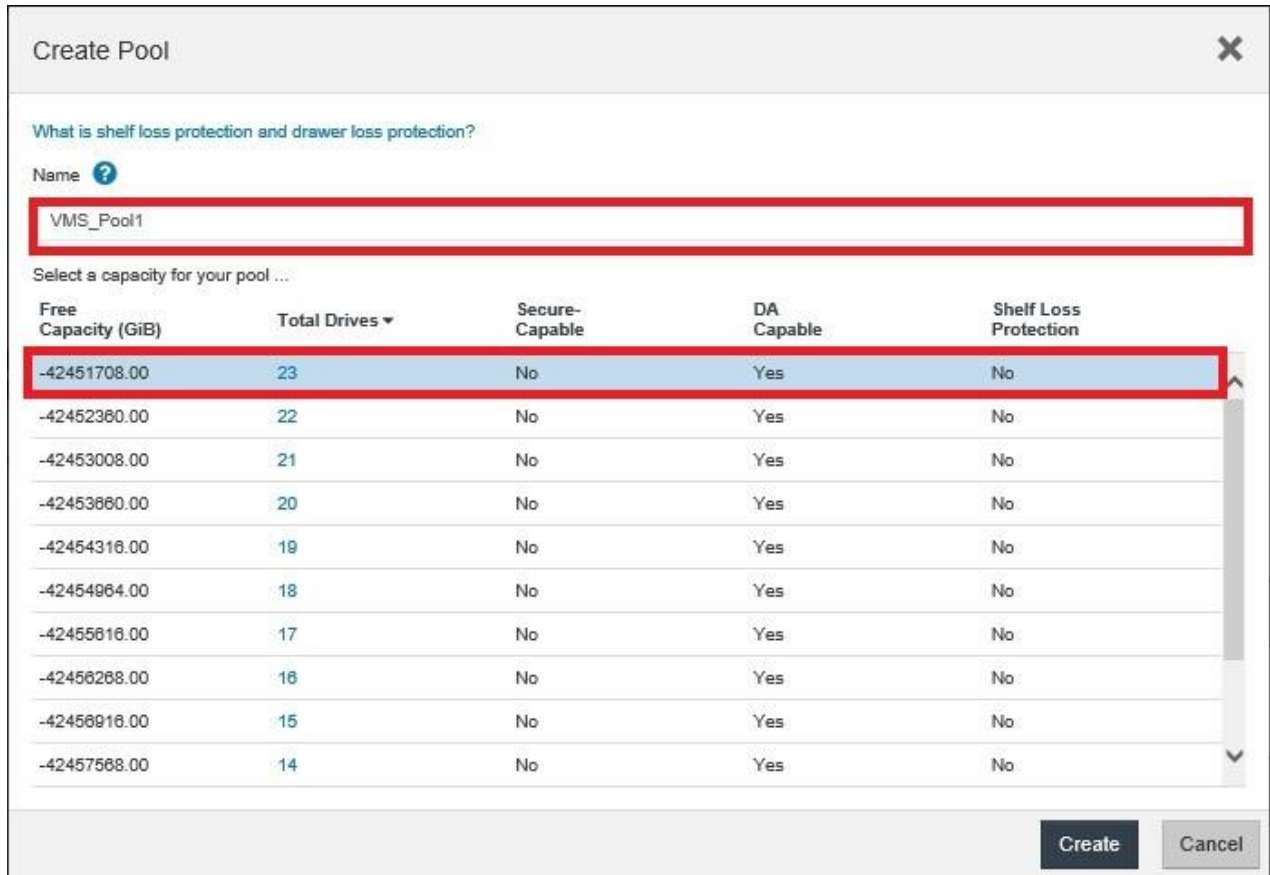

After you create your pool, the dialog box in Figure 6 appears. Here, you can see that the pool called VMS\_Pool1 has 42451708.00GiB free, so now you can create some volumes. Click the Create drop-down menu, and click Volumes.

Figure 6) Create a volume.

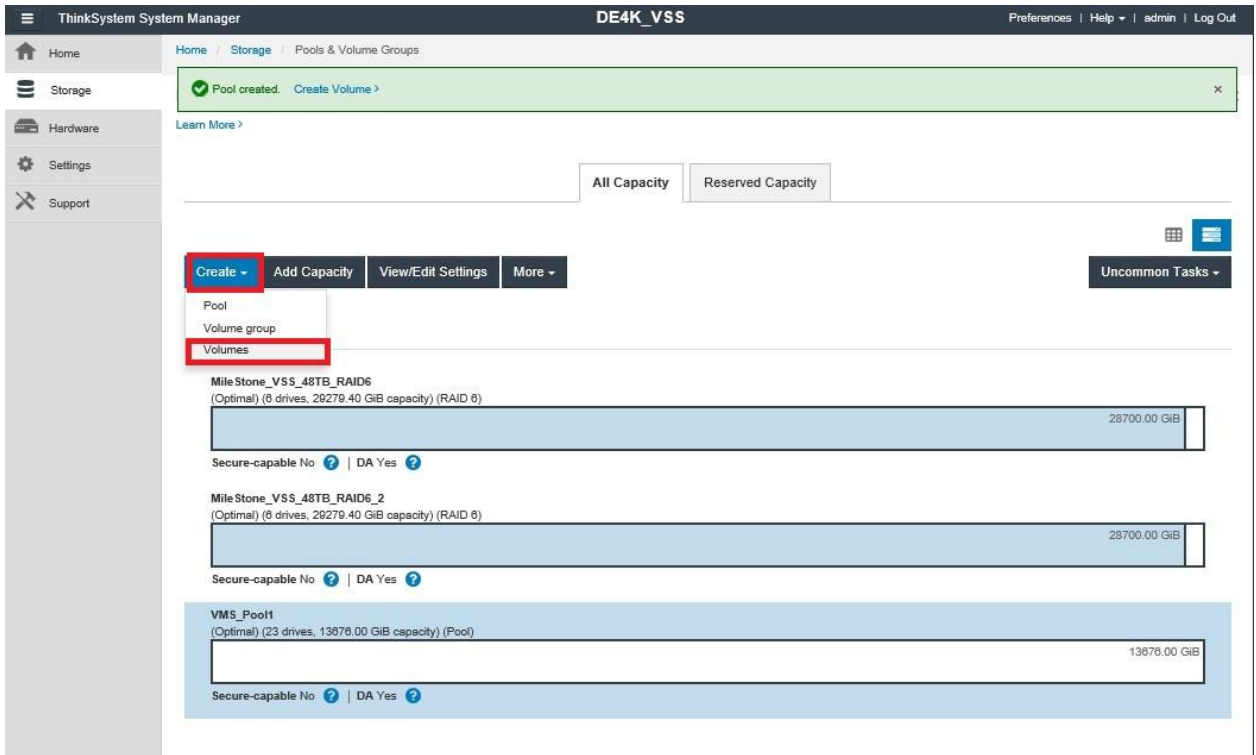

On DE Series systems, be sure to create at least two volumes on each system. Having two volumes enables both controllers in the DE Series array to actively contribute to the performance of the system. Figure 7 shows the creation of two volumes on VMS\_Pool1. These volumes are named VMS\_Vol1 and VMS\_Vol2.

Figure 7) Create a volume (continued).

**Create Volumes** [Close]

1 Select Host | 2 Select Workload | **3 Add/Edit Volumes** | 4 Review

**(Optimal) (8 drives, 29279.40 GiB capacity) (RAID 6)**

28700.00 GiB

Secure-capable No ? | DA Yes ?

+ Add new volume

**Mile Stone\_VSS\_48TB\_RAID6\_2** [Allocated] [Proposed] [Free]

(Optimal) (8 drives, 29279.40 GiB capacity) (RAID 6)

28700.00 GiB

Secure-capable No ? | DA Yes ?

+ Add new volume

**VMS\_Pool1** [Allocated] [Proposed] [Free]

(Optimal) (23 drives, 13878.00 GiB capacity) (Pool)

13000.00 GiB

Secure-capable No ? | DA Yes ?

<input checked="" type="checkbox"/>	Volume Name	Reported Capacity		
<input checked="" type="checkbox"/>	VMS_Vol1	6500	GiB	✕
<input checked="" type="checkbox"/>	VMS_Vol2	6500	GiB	✕

+ Add new volume

< Back [Cancel] Next >

Figure 8 shows what the system configuration looks like after you have allocated all the storage on the system.

Figure 8) Example of final volume configuration.

**Note:** Before you can create hosts as shown in the following example, you must perform some setup on the attached server or servers. You can find those steps on the [Lenovo Support Site](#) under the software installation, configuration, and upgrade section for your OS.

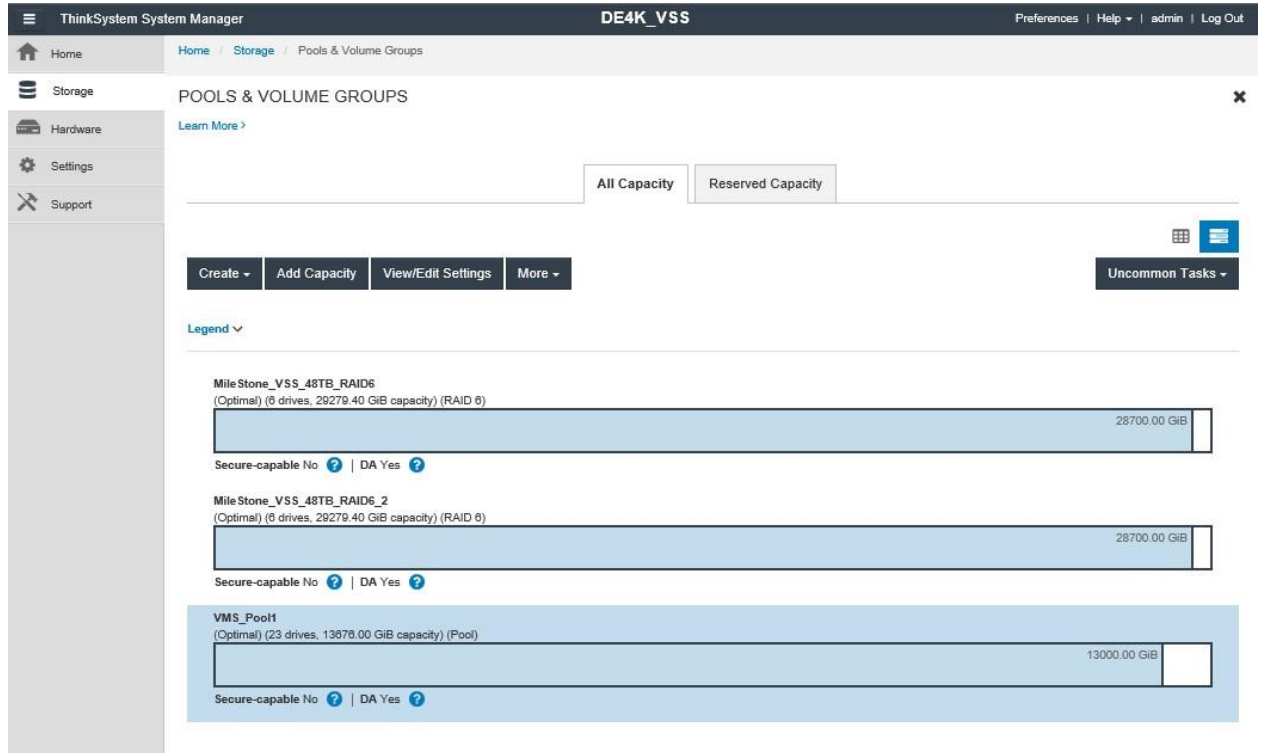

Because iSCSI is used as the protocol in this example, Figure 9 and Figure 10 show where you configure your iSCSI ports. To enable communication with the DE Series storage array, discovery from the host side is required. To navigate to Configure iSCSI Ports (Figure 10), click the Settings tab and then click the System tile as shown in Figure 9.

Figure 9) iSCSI settings.



In the System menu, scroll down to the iSCSI Settings section, which contains the Configure iSCSI Ports link that is shown in Figure 10. From there, you can configure your IPs for the iSCSI ports.

**Note:** Also outlined in Figure 10 is the target iSCSI Qualified Name (IQN). If you are

connecting to multiple DE Series storage arrays and need to differentiate between arrays, this setting might come in handy.

Figure 10) iSCSI settings (continued).

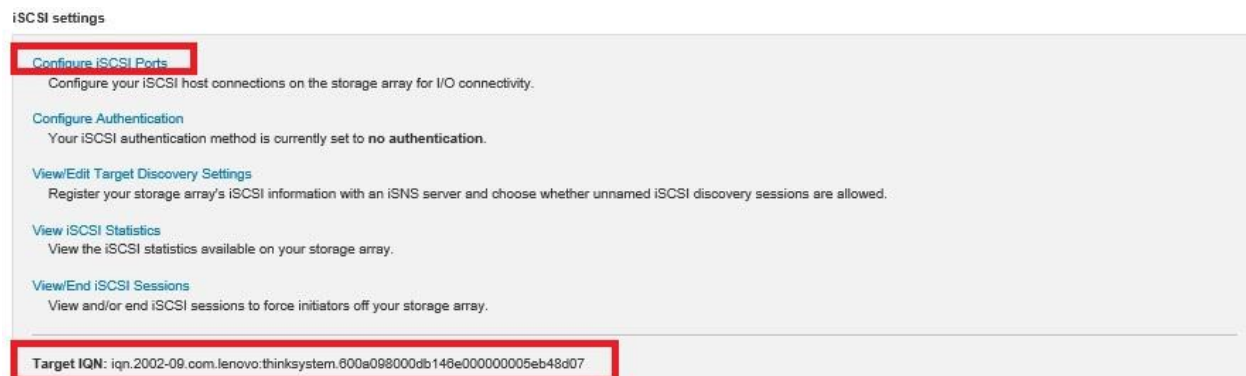

Finally, after you create your volumes (and after you set up iSCSI sessions if you use the iSCSI protocol), you can create hosts and map volumes to hosts. After you create your volumes, return to the home screen, click the Storage tab on the left, and then click the Hosts tile as shown in Figure 11.

Figure 11) Create a host.

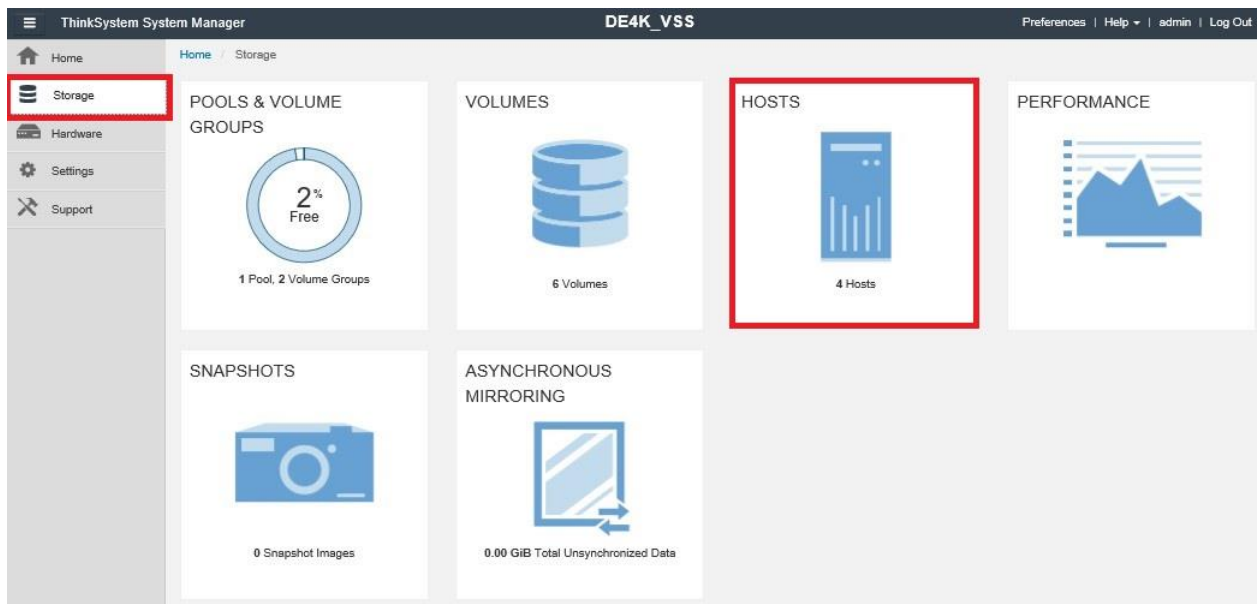

After you click the Hosts tile, the dialog box in Figure 12 appears. Simply click Create Host.

Figure 12) Create a host (continued).

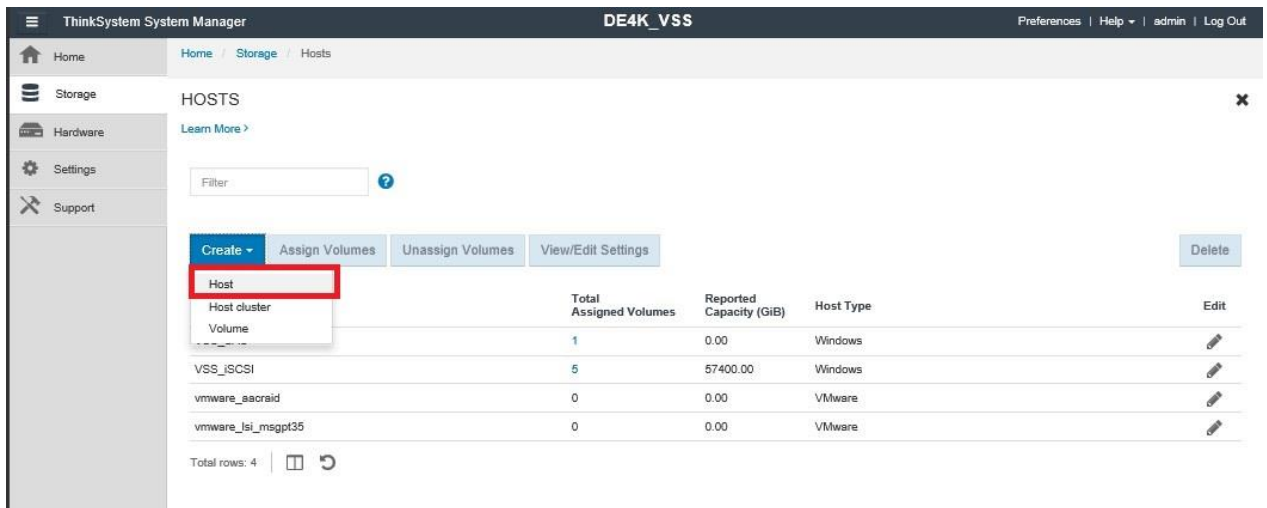

In the following dialog box in Figure 13, you must provide a name for your host, select the OS, and select the IQN of the host. After you have completed that information, click Create, then your host is available for you to assign volumes to it.

Figure 13) Host definitions.

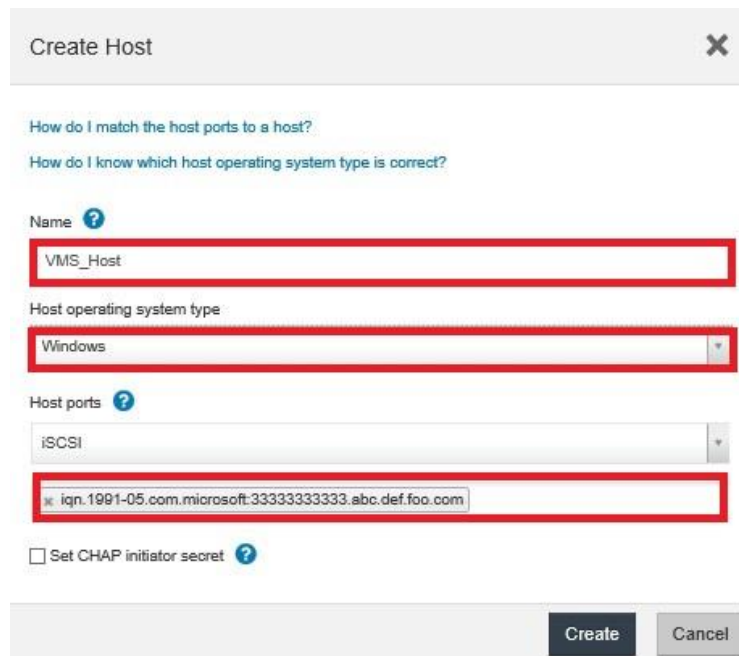

After you have defined the host, the dialog box in Figure 14 appears. Here, you click the Assign Volumes button and assign the volumes that you created previously.

Figure 14) Assign volumes to the host.

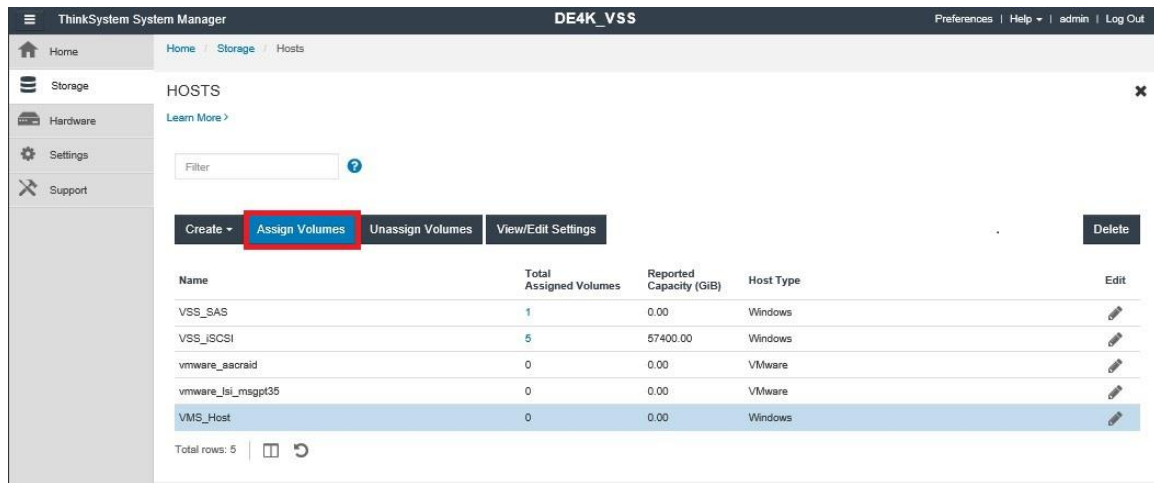
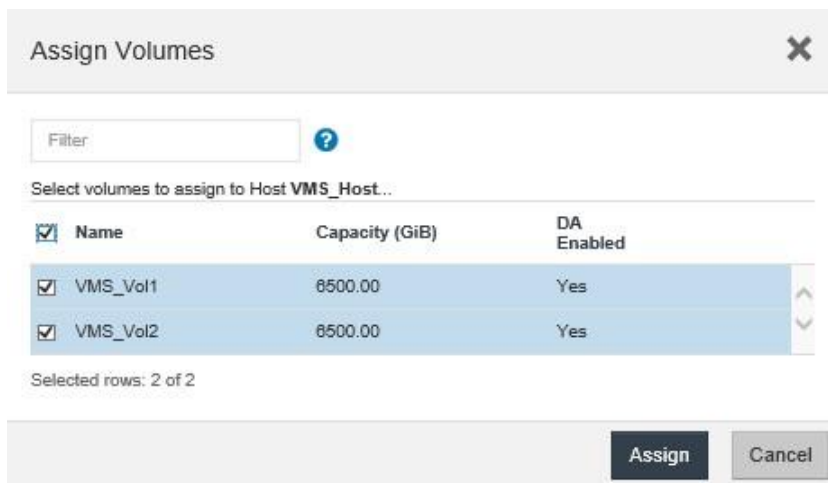

Figure 15 shows the Assign Volumes dialog box. Here, you see the volumes that you have created. Check the boxes next to the volumes that you want to assign to the particular host that you selected in Figure 14.

Figure 15) Select volumes to assign.



Finally, in Figure 16, you can see that VMS Host now has two volumes assigned to it. From the server side, you can now use the volumes as storage.

Figure 16) Host with assigned volumes.

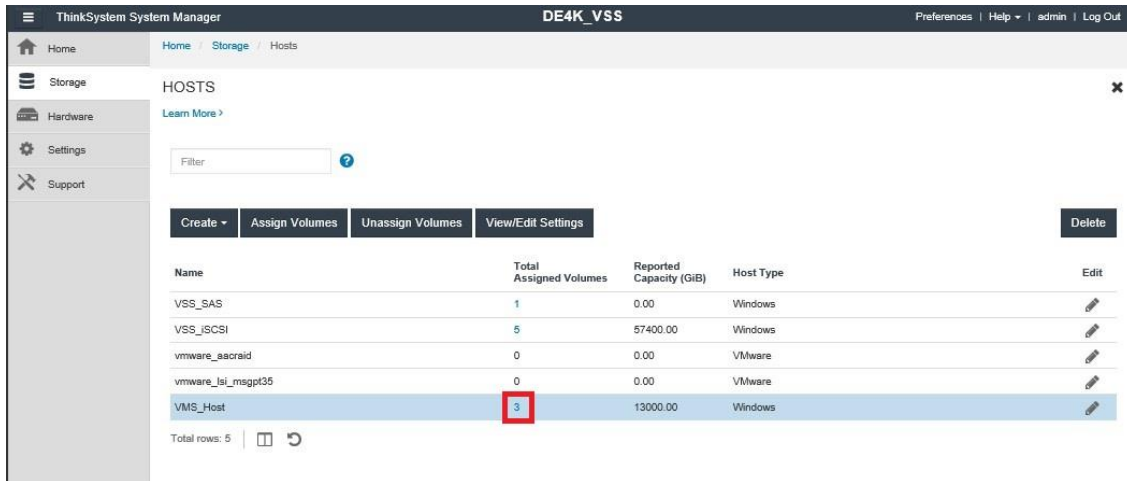

## 6 Server Considerations

This section focuses on recording and failover server requirements.

The recording server represents one or more instances of the hardware and software that are used to record live video or to archive video to the storage array. The software can run on a physical machine or as a guest on a virtual machine. The guest virtual machine must have the same virtual memory and virtual CPU as specified by the video management system software requirements for a physical machine.

The number of networked video cameras per recording server and the resulting data rate are determined by the architecture and best practices that are documented by your VMS provider. As a general principle, and depending on your system hardware specifications, the amount of video that any individual server can process ranges from 100Mbps to 600Mbps.

Table 7 lists the general recording server characteristics that Lenovo recommends.

Table 7) Recording server characteristics that Lenovo recommends.

Characteristic	Description
Form factor	1 RU for space savings
CPU	Quad-core in the 2.0GHz to 2.9GHz frequency range
RAM	8GB or higher
Network adapters	Integrated Ethernet adapters and PCI-based quad-port 1Gbps/10Gbps Ethernet for video ingress and, optionally, IP SAN connectivity
Internal drives	Dual RAID 1 (internal RAID controller) for a high-availability boot drive
OS	Windows 2012 or later
Recording volume file system	NTFS (allocation unit size: 64KB)

**Note:** For the latest hardware and software requirements, go to your VMS provider's website.



## 6.1 Multipath I/O Device-Specific Module Installation

As described in section 4.5, High Availability, Lenovo DE Series arrays support multiple paths to the LUNs from a server. To manage these paths, you must download the appropriate Lenovo Storage Manager software from the [Lenovo Support Site](#), and you must install the software on each server.

Windows MPIO feature must be enabled first and the system is rebooted before installing the Windows DSM. When you install the ThinkSystem Storage Manager software, use the Custom installation option and then select the items that are shown in Figure 17. This step installs the host MPIO DSM and the utilities files. If you are asked to start a background monitor process or agent, do not select this option, or select No.

Figure 17) Lenovo ThinkSystem Storage Manager installation.

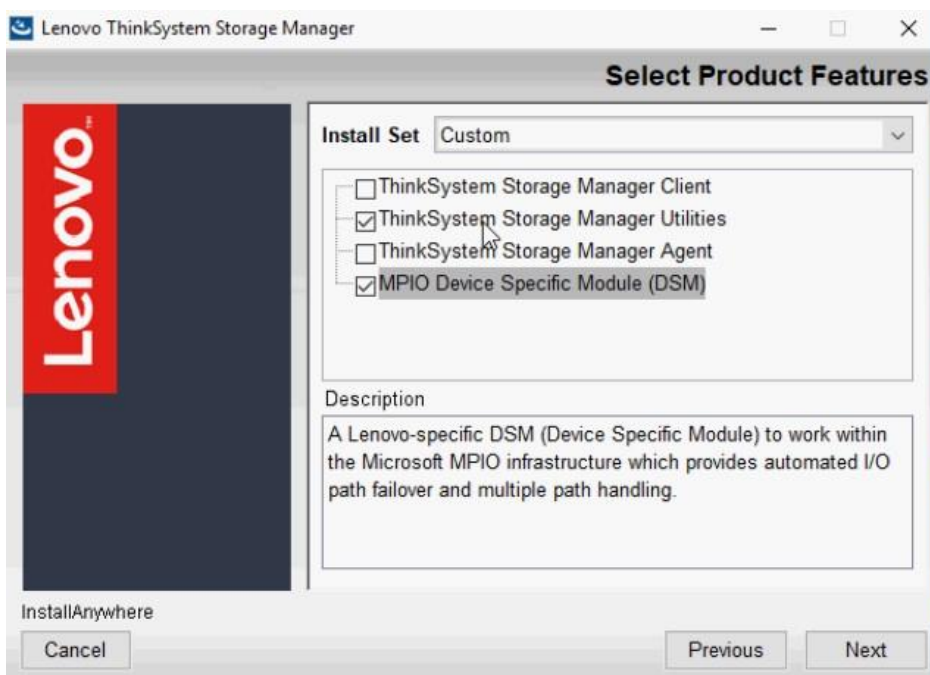

**Note:** For more help, go to the [Lenovo Support Site](#).

## 6.2 DE Series LUN Discovery and Preparation

After the appropriate LUNs have been mapped to the recording server as shown in section 5, Lenovo DE Series Storage Provisioning, you should perform the following steps:

1. Navigate to:

```
C:\Program Files\ThinkSystem\StorageManager\util
```

2. Run the command `SMdevices`; it should list all the DE Series LUNs that are mapped to the server and display various information, including the current and preferred controllers.
3. Use the information that `SMdevices` reports to help you in mapping DE Series LUNs to drive letters in the Windows Disk Management tool. The Windows Disk Management tool identifies an DE Series LUN as a drive that must be initialized, formatted, and mapped to a drive letter before I/O can be issued to that drive. The tool is used to view and to set details, such as the configuration of drive type, volume name, and allocation unit size. For video surveillance implementation, Lenovo recommends an allocation unit

size of 64KB.

**Note:** For more information about Windows Disk Management, read the [overview from Microsoft](#).

## 7 Networking Considerations

The network infrastructure for video surveillance deployments must meet the following requirements:

- Provide sufficient available capacity (bandwidth) to transport video.
- Exhibit very low or no loss of IP video packets.
- Feature network latency that is within a suitable range for the transport protocol (TCP or User Datagram Protocol [UDP]) of the video feed.
- Provide high availability through network redundancy and best practices in network design.
- Satisfy the network security and services requirements.

To meet the preceding requirements, for Lenovo DE Series systems, Lenovo recommends a 10Gb Ethernet network at a minimum. The DE2000H, DE4000H and the DE6000H systems have two onboard host ports per controller that support either 10Gb iSCSI or 16Gb FC. Figure 18, Figure 19 and Figure 20 show these host ports on the top left of each controller.

For iSCSI deployments, the use of multiple Ethernet network interface cards (NICs) connecting to dual IP SANs also provides high availability to the DE Series controllers. For other protocols, such as FC or SAS between the server and the DE Series controllers, dual-port host bus adapters (HBAs) provide redundant paths to each controller.

Figure 18) Back view of the DE2000 controller.

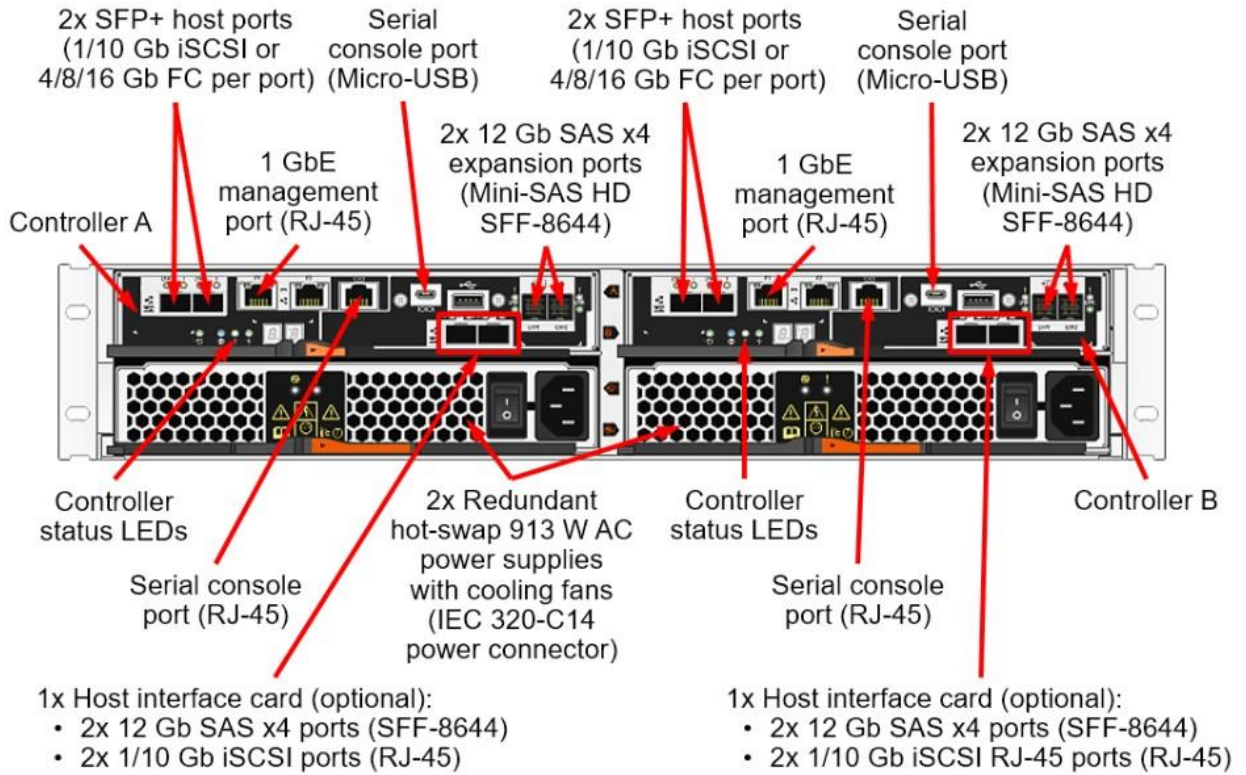

Figure 19) Back view of the DE4000 controller.

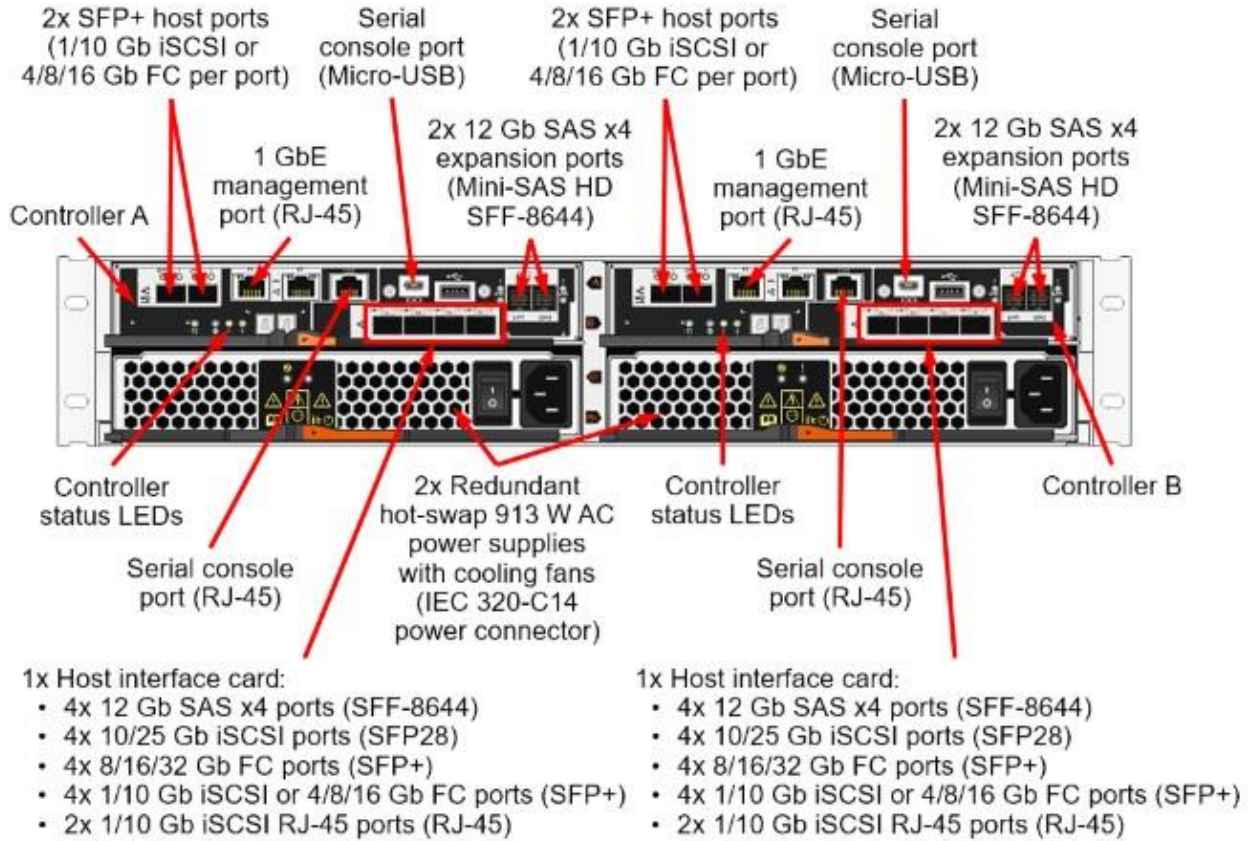
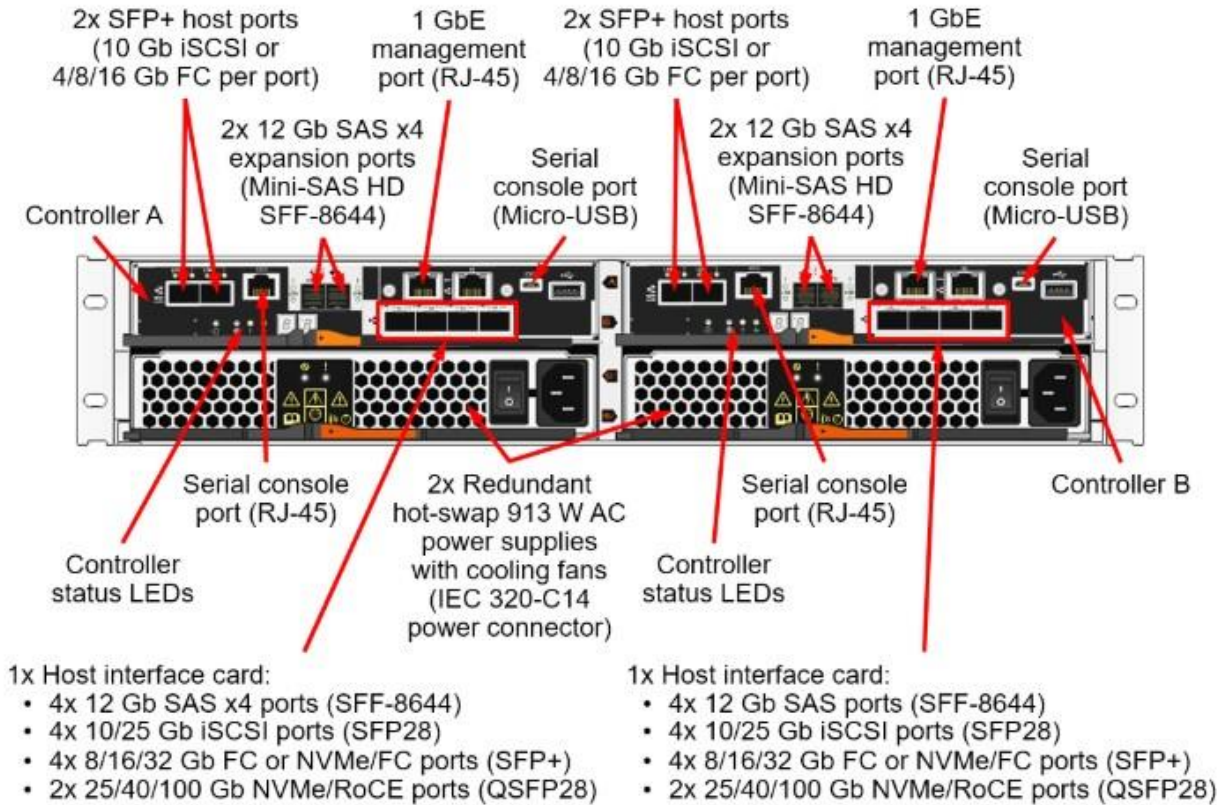

Figure 20) Back view of the DE6000 controller.



## 7.1 Traffic Management

To maintain a high-performing network, use multiple NICs to separate the camera network, the client network, and SANs. By separating these networks, you gain the following benefits:

- **Increased performance.** By separating the traffic, you eliminate the impact on recording performance that a high load on a client network might have.
- **Stability.** With separated networks, interference on the client network does not affect the camera network, which promotes predictable performance.
- **Increased security.** No accidental or intentional interference with camera operations occurs. By isolating the camera network, you eliminate the possibility of devices sending information through the internet without your knowledge or permission.
- **Improved management.** Management is also easier because the load is independent to each network. These independent loads make it easier to calculate and to measure the bandwidth usage on each network.

**Note:** As a best practice, be sure to eliminate single points of failure. An example is to implement a secondary SAN switch. If a switch fails, your recording servers have an additional path to your Lenovo DE Series storage and cameras can continue recording.

## Where to Find Additional Information

To learn more about the information that is described in this document, review the following documents and websites:

- Virtualizing Video Management Systems with Lenovo DE Series Storage  
<https://www.lenovo.com/us/en/resources/data-center-solutions>
- ThinkSystem Storage Documentation  
<https://thinksystem.lenovofiles.com/storage/help/index.jsp>

## Contacting Support

You can contact Support to obtain help for your issue.

You can receive hardware service through a Lenovo Authorized Service Provider. To locate a service provider authorized by Lenovo to provide warranty service, go to <https://datacentersupport.lenovo.com/serviceprovider> and use filter searching for different countries. For Lenovo support telephone numbers, see <https://datacentersupport.lenovo.com/supportphonenumberlist> for your region support details.

## Notices

Lenovo may not offer the products, services, or features discussed in this document in all countries. Consult your local Lenovo representative for information on the products and services currently available in your area.

Any reference to a Lenovo product, program, or service is not intended to state or imply that only that Lenovo product, program, or service may be used. Any functionally equivalent product, program, or service that does not infringe any Lenovo intellectual property right may be used instead. However, it is the user's responsibility to evaluate and verify the operation of any other product, program, or service.

Lenovo may have patents or pending patent applications covering subject matter described in this document. The furnishing of this document is not an offer and does not provide a license under any patents or patent applications. You can send inquiries in writing to the following:

*Lenovo (United States), Inc.*

*8001 Development Drive*

*Morrisville, NC 27560*

*U.S.A.*

*Attention: Lenovo Director of Licensing*

LENOVO PROVIDES THIS PUBLICATION "AS IS" WITHOUT WARRANTY OF ANY KIND, EITHER EXPRESS OR IMPLIED, INCLUDING, BUT NOT LIMITED TO, THE IMPLIED WARRANTIES OF NON-INFRINGEMENT,

MERCHANTABILITY OR FITNESS FOR A PARTICULAR PURPOSE. Some jurisdictions do not allow disclaimer of express or implied warranties in certain transactions, therefore, this statement may not apply to you.

This information could include technical inaccuracies or typographical errors. Changes are periodically made to the information herein; these changes will be incorporated in new editions of the publication. Lenovo may make improvements and/or changes in the product(s) and/or the program(s) described in this publication at any time without notice.

The products described in this document are not intended for use in implantation or other life support applications where malfunction may result in injury or death to persons. The information contained in this document does not affect or change Lenovo product specifications or warranties. Nothing in this document shall operate as an express or implied license or indemnity under the intellectual property rights of Lenovo or third parties. All information contained in this document was obtained in specific environments and is presented as an illustration. The result obtained in other operating environments may vary.

Lenovo may use or distribute any of the information you supply in any way it believes appropriate without incurring any obligation to you.

Any references in this publication to non-Lenovo Web sites are provided for convenience only and do not in any manner serve as an endorsement of those Web sites. The materials at those Web sites are not part of the materials for this Lenovo product, and use of those Web sites is at your own risk.

Any performance data contained herein was determined in a controlled environment. Therefore, the result obtained in other operating environments may vary significantly. Some measurements may have been made on development-level systems and there is no guarantee that these measurements will be the same on generally available systems. Furthermore, some measurements may have been estimated through extrapolation. Actual results may vary. Users of this document should verify the applicable data for their specific environment.

## Trademarks

LENOVO, LENOVO logo, and THINKSYSTEM are trademarks of Lenovo. All other trademarks are the property of their respective owners. © 2020 Lenovo